

Evaluation of Zero Tillage Drill for Mungbean Establishment in the Farmers Field

Md. Shamshad Ansari, Scientist, DoAR, Tarahara¹, Manoj Kumar Joshi, Technical Officer, DoAR, Tarahara², Santosh Kumar Shreestha, DoAR, Tarahara²

Received 15 December 2022; Accepted 30 December 2022

ABSTRACT

The conventional method of mungbean (*Vigna radiata*) cultivation is direct broadcasting involves land preparation and seeding which is laborious, time-consuming and cost-intensive. Conservation agriculture-based technologies are becoming increasingly popular among the farmers due to having early planting scope, the minimum cost of production, improving soil health and sustainable environment. This study was conducted to evaluate the performance of a power tiller operated zero-till drill for the adoption in mungbean cultivation. Overall performance was evaluated based on seed rate, number of plants per unit area, number of pods per plant, number of seeds per pod and grain yield, net saving and benefit-cost ratio, and compared with the conventional method. Results showed that average seed rate was 30.0 kg/ha and 35.5 kg/ha for zero tillage and conventional method respectively, which indicates that 5.5 kg of seed per ha was saved with zero tillage system. Besides, zero tillage system could maintain a uniform depth of planting with better seed-soil contact. The average number of plants, pods per plant, seed per pods and yield per hectare were higher in zero tillage system compared to the conventional method. Mungbean yield under zero tillage system was 30.4% higher than the conventional method. Furthermore, from an economic viewpoint, zero tillage system is suitable for mungbean cultivation because it could save the production cost by 20.9% and increased net saving by 60.9% than the conventional method. Furthermore, a higher benefit-cost ratio was obtained from the zero tillage system (BCR = 3.2) than the conventional system (BCR = 1.6) which indicates that zero tillage system is profitable than the conventional method.

Keywords: Zero tillage, Broadcasting, Reduced tillage, Conservation agriculture, Zero-till drill

I. Introduction

Tillage is the mechanical manipulation of soil to create a favorable condition for seed and plants. Conventional tillage methods have long resulted in exposed field surface, decrease soil fertility, serious water loss and soil erosion and increasingly deteriorating ecological environment. To achieve sustainable development in agriculture, it is time demand to promote the systematized protective tillage techniques and implements for the preservation of soil moisture suitable to the intensive farming areas. Hatfield and Karlen (1992) reported that the adoption of reduced tillage methods can offer significant environmental benefits over conventional tillage system.

Conservation agriculture-based tillage technologies like zero tillage, reduced tillage, strip tillage and bed planting are gaining popularity among the farmers due to having distinct advantages over the conventional tillage. According to Hobbs *et al.* (2008), conservation agriculture-based tillage technology results in less soil disturbance, crop residue management and following beneficial crop rotation. Among the conservation agriculture-based technologies, zero tillage is more beneficial in terms of less soil degradation, enhancing microbial activities, more efficient use of inputs and improving soil fertility and sustainable environment (Sharma *et al.*, 2008; Kahloon *et al.* 2012). In zero tillage system, the establishment of the crop is done in previously unprepared soil by opening a narrow slot or band only of sufficient width and depth to obtain proper seed placing which reducing land preparation cost and less soil disturbance due to reducing the number of tillage operation and thus the number of tractor and tillage implement trips over the soil (Qaisrani *et al.*, 2014). Besides, zero tillage system with residue management helps in conserve soil moisture and a natural increase of organic matter in topsoil (Derpsch *et al.*, 2010). Power tiller (two-wheel tractor) operated conservation agriculture technologies have been developed by different organizations among which zero tillage and strip tillage technologies are more viable for dry soil. To evaluate the field performance of developed conservation agriculture technologies, different promotional activities are being conducted in the farmer's field in Bangladesh. Most of the previous promotional activity was conducted under rice-wheat or rice-maize cropping system. This research was carried out to evaluate the performance of BARI (Bangladesh Agricultural Research Institute) developed power tiller operated zero-till drill for the establishment of mungbean.

Mungbean is a leguminous crop which envisioned as the best of all pulses from the nutritional

viewpoint. Whole mungbean seed contains 62.6% carbohydrate, 23.9% protein, 4% minerals and 3% vitamins (USDA, 2018). However, mungbean cultivation like other pulses is decreasing due to less yield and higher production cost as well as the expansion of boro rice cultivation area. Though crop scientists are trying to increase the yield through varietal development it is necessary to reduce production cost through introduction of proper management practice (Uddin *et al.*, 2009). In Bangladesh, mungbean is cultivated after T. Aman rice or wheat using conventional tillage through manual broadcasting which is laborious, time-consuming and cost extensive. Also, planting of mungbean depends on the previous harvest which often delayed due to unavoidable weather condition. Thereby, reducing crop yield since timely planting and harvesting are the key operations for achieving the desired yield. Besides, long turn-around time can be caused by excessive tillage, soil moisture problems, shortage of animal or mechanical power for ploughing and other farm jobs like threshing and managing rice crop or wheat before preparing land for mungbean cultivation. Erensten and Laxmi (2008) reported that zero tillage system is appropriate for wheat cultivation after rice in rice-wheat cropping system allowing earlier wheat planting, helping control the weed, reducing production cost and saving water. Furthermore, according to Naresh *et al.* (2013), the conversion of conventional to zero tillage can result in higher bulk density and infiltration and lower runoff compared to conventional tillage. Therefore, the adoption of zero tillage system for mungbean cultivation could help the farmers to decrease production cost and increase net saving. The specific objectives of this research are to evaluate the field performance of power tiller operated zero-till drill for the establishment of mungbean and compare the field and economic performance of zero-till drill with the conventional method.

II. Materials and Methods

Field tests were conducted at Bangladesh Agricultural University Farm to evaluate the performance of a zero-till drill for the establishment of mungbean. During planting operation, the zero-till drill was attached with a 12 HP Dongfeng power tiller which is very common in Bangladesh to complete the planting operation. Binamoog-5 was used as test variety of mungbean. Planting depth and seed covering mechanism were kept constant throughout the planting operation. Before planting operation, a herbicide named “Roundup” was applied to kill the existing weed at the rate of 100 ml in 10-litre water for 5 decimal lands.

Zero-till drill machine

An isometric diagram of BARI developed power tiller operated zero-till drill is shown in Fig.1. Technical detail of zero-till drill is given in Table 1. The overall performance of the zero-till drill for the establishment mungbean was also compared with the conventional broadcasting system.

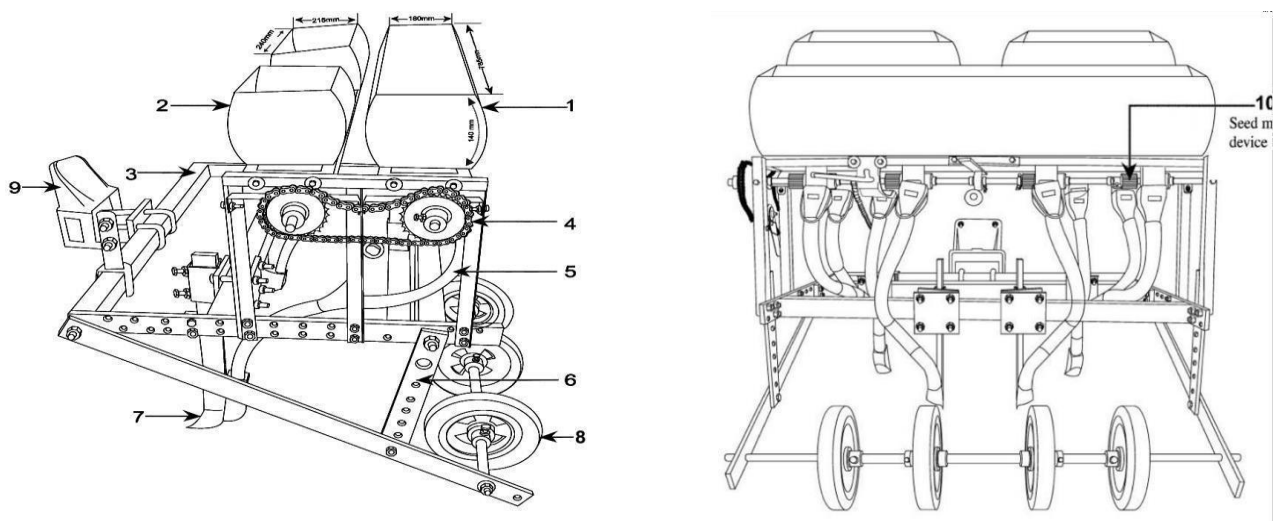

1. Seed box, 2. Fertilizer box, 3. Toolbar frame, 4. Chain and sprocket, 5. Seed tube, 6. A depth control device, 7. Furrow opener 8. Press wheel 9. Hitch plate 10. Seed metering device

Fig. 1. An isometric view of zero-till drill machine (Ansari *et al.*, 2016) Table 1. Technical specification of zero-till drill used for the establishment of Mungbean

Evaluation of Zero Tillage Drill for Mungbean Establishment in the Farmers Field

Particulars	Number	Dimension (mm)	Material
Hitch plate	1	255 × 230 & 130 × 135	MS steel
Toolbar frame	1	980 × 660	MS bar
Seed box	1	810 × 210 × 180	Plain sheet
Fertilizer box	2	850 × 240 × 160	Plain sheet
Seed tube	4	100 × 170 × 90	Plastic
Furrow opener	4	233 × 125	Heavy flat bar
Press wheel	4	280 × 50	Rubber
Depth control devices	2	270 × 360	MS bar
Seed metering device	4	Flute type	Moulded plast
Power transmission system	1	Roller-420	Roller chain
Chain-Sprocket	2	22 and 19 teeth	Steel
Clutch	1	dog clutch	MS iron

Calibration of zero-till drill for seed rate:

Before the actual planting operation, the zero-till drill was calibrated for correct seed rate. During calibration for seed rate, two-third of the seedbox was filled with seed and transparent polythene bags were tagged with each of the seed delivery tubes. After that zero-till drill was operated on a pre-measured 20 m travel distance with a sowing width of 80 cm. Then, seed collected in polythene bags that passed through tubes were weighed and seed rate was determined according to the equation (1) as described by Michael and Ojah (1978). This procedure was repeated by adjusting the seed metering device until the desired seed rate obtained. The seed rate was kept at 30.0 kg/ha for zero-till drill.

$$S_d = \frac{10 W_s}{A_m} \dots\dots\dots (1)$$

Where,

S_d = Seed rate (kg/ha)

W_s = Total weight of seed (gm)

A_m = Measured experimental area, m²

Land preparation

Land preparation was not required for the establishment of mungbean under zero tillage system. However, land preparation was a precondition for the cultivation of mungbean in the conventional method. The land was Ploughed by 3 passes of power tiller followed by 2 passes of laddering with straight alternation pattern. Land size of 11.20 decimals with 3 replication plots for each cultivation method was prepared.



(a) The conventional method of planting

Fertilizer application:

As mungbean is a leguminous crop which can store nitrogen in its root zone from the air. So only TSP fertilizer was applied at the rate of 100 kg/ha during planting followed by the broadcasting method in both zero-tillage system and conventional method.

Experimental procedure

During mungbean planting time, the average moisture content of the soil for the top 50 mm was 25% (dry basis). In the case of zero tillage system, the seed was applied in an untilled previously harvested rice field. Straight alternation pattern was used for sowing. For proper seed placement, the speed of operation was maintained at 2.5 km/hr. In the conventional system, both seed and fertilizer were sown by manual broadcasting after the second pass of ploughing followed by laddering. After sowing/planting operation, all the cultural practices such as fertilizer application, irrigation and plant protection were done in all the plots as per the agronomical requirement. A photographic view of mungbean establishment using a zero-till drill and conventional method were shown in Fig. 2.



(a) Zero tillage system of planting

Fig. 2. Photographic views of mungbean establishment in the field

Zero-till drill for the establishment of mungbean Performance evaluating parameters

Overall performance of zero tillage and conventional system in mungbean cultivation was evaluated based on-field performance, yield and yield contributing parameters and economic of performance.

Field performance

Field performance of zero-till drill was evaluated based on field capacities, field efficiency and seed rate. Amount of seed required per hectare area was calculated using Equation (1). And field capacities and field efficiency were calculated using equation (2), (3) and (4) according to Kepner *et al.* (1978).

$$\text{Theoretical field Capacity (ha/hr)} = \frac{SW}{10} \dots\dots\dots(1)$$

$$\text{Effective field Capacity (ha/hr)} = \frac{\text{Area Covered}}{\text{Time Required}} \dots\dots\dots(3)$$

$$\text{Field Capacity} = \frac{\text{Effective Field Capacity}}{\text{Theoretical Field Capacity}} \times 100 \dots\dots\dots(4)$$

Where, S = Rated forward speed for zero-till drill, (km/hr),
 W = Rated width of the machine (m)

Yield and yield contributing parameters:

Yield and yield contributing parameters of mungbean cultivation under zero tillage system and the conventional method were evaluated based on the number of plants per unit area, number of pods per plant, number of seeds per pod and total grain yield per hectare.

Economic of Performance:

Economic of performance of zero tillage system and conventional method for mungbean cultivation was evaluated based on the cost of mungbean establishment, the total cost of production, total output, net saving and benefit-cost ratio (BCR). In the case of zero tillage system, mungbean establishment cost consists of seed cost and planting cost, whereas the conventional method consists of seed cost, land preparation and seeding cost.

Zero-till drill operational cost:

Operating cost of zero-till drill consists of fixed cost like depreciation cost, interest on investment, taxes, insurance and shelter cost, and variable costs like repair and maintenance cost, fuel cost, oil cost and labour cost. All parameters of operational cost were calculated using the standard formula (Hunt, 1973; Singh et al., 2016).

Fixed cost:

Fixed cost is defined as one which remains unchanged regardless of the level of output alters. In this research, depreciation cost, interest on investment and shelter cost was taken into account as fixed cost items. The straight- line method of depreciation analysis was used to calculate the depreciation cost of the zero-till drill as shown in equation (5). Since the invested money cannot be used for other interest making business, interest on investment was take into account and was calculated using equation (6) and shelter cost which is necessary to protect a machine against adverse weather conditionwas calculated using equation (7).

$$\text{Depreciatøn Cost (Tk/hr)} = \frac{P - S}{L * H} \dots\dots\dots(5)$$

$$\text{Intereston Investment(Tk/hr)} = \frac{P + S}{2} \times \frac{i}{H} \dots\dots\dots(6)$$

$$\text{Shelter Cost (Tk/hr)} = \frac{1\% \text{ of } P}{H} \dots\dots\dots(7)$$

Where, P = purchase price of a zero-till drill (Tk.); S =salvage value i.e. 10% of purchase price (Tk.); i = interest rate i.e. 10%; L = life of zero-till drill, 7 year, H = annual use of zero-till drill, 300 hr

Variable cost:

Variable cost is defined as one which changed with the changing level of output. In this research repair and maintenance cost and hiring cost for power tiller were considered as a variable cost. Repair and maintenance cost of the zero-till drill was calculated using equation (8)and power tiller was hired during this experiment @ Tk. 150 per hour including fuel cost, oil cost and operator cost.

$$\text{Repair and Maintenance Cost (Tk/hr)} = \frac{5\% \text{ of } P}{H} \dots\dots\dots(8)$$

Land preparation cost in conventional method was calculated as 3 passes of ploughing by power tiller @ Tk.1200 per pass plus 2 passes of laddering @ Tk. 400 per pass.

Land preparation cost in conventional method was calculated as 3 passes of ploughing by power tiller@ Tk.1200 per pass plus 2 passes of laddering @ Tk. 400 per pass.

Benefit-cost ratio (BCR)

It is a ratio used in a cost-benefit analysis to summarize the overall relationship between the relative costs and benefits of a proposed project. If a project has a BCR greater than 1.0, the project is expected to deliver a positive net present value to a firm and its investors. It was calculated using equation (9).

$$\text{Benefit Cost Ratio (BCR)} = \frac{\text{Netsaving from a project}}{\text{The total cost of production}} \dots\dots\dots(9)$$

III. Results and Discussion

Field performance

Field performance of zero-till drill and conventional method for the establishment of mungbean was evaluated based on seed rate, a line to line spacing and depth of planting. Parameters related to field performance of zero- till drill and conventional methods are shown in Table 2. From Table 2, it is observed that applied seed rate was 30.0 kg/ha in the zero-tillage system and 35.5 kg/ha in the conventional method. Therefore, zero tillage system required 5.5 kg less seed per hectare compare to the conventional system. Besides, a line to line space was 20 cm and the average width of opening slits was 2.0-3.0 cm and depth of planting was 3.0-3.5 cm in zero tillage system. The adjustment of row spacing between two successive passes was maintained by operator skill and experience. However, seed spacing and depth of seeding were found uneven in the conventional method which is due to broadcasting and laddering.



(a) Conventional method



(b) Zero tillage system

Fig. 3. A photographic view of the growing stage of Mungbean with different sowing method after 7 days from seeding

Table 2. Field performance of different tillage method for mungbean establishment

Parameters	Zero-till drill	Conventional method
Line to line distance (cm)	20	Scattered
Depth of planting (cm)	3-3.5	Uneven
Effective field capacity (ha/hr)	0.12	0.18
Field efficiency (%)	73.35	78.5*
Seed rate (kg/ha)	30	35.5
Fuel consumption (l/ha)	9.3	18.2*

* Plowing operation

Table 3. Yield and yield contributing parameters of mungbean cultivated under different tillage system

Methods	Ave. No. of plants/m ²	Ave. No. of Pods/plant	Ave. No. of Seeds/pod	Grain yield (kg/ha)	Yield Increased(%)
Zero-till drill	108	45	11.4	1247.5	30.4
Conventional (Broadcasting)	87	31	8.8	956.5	-

Yield and yield contributing parameters

A photographic view of the growing stage of mungbean established by zero tillage system and the conventional method is shown in Fig. 3. From the figure, it is observed that vegetative growth of mungbean was better under zero tillage system compared to the conventional method. Yield and yield contributing parameters of mungbean under zero tillage and the conventional method were evaluated based on number of plants per unit area, number of pods per plant, number of seeds per pod and grain yield. Yield and yield contributing parameters of mungbean cultivated under zero tillage and conventional method are shown in Table 3.

Economic analysis

The economics of performance of zero tillage system and conventional method for the establishment of mungbean was evaluated based on the cost of planting, total cost of production, total output, net saving and benefit-cost ratio (BCR). Operating cost of the zero-till drill for the establishment of mungbean was found Tk. 1515/ha as shown in Table 4. The planting cost of mungbean including seed cost under zero tillage and the conventional method was Tk. 4515/ha and Tk. 8400/ha, respectively (shown in Table 5). From Table 5, it is observed that the establishment cost-saving for mungbean under zero tillage system was Tk. 5485/ha (65.3%) over the conventional method. This result is following Sindh et al. (2007) who reported that the cost of establishment of wheat under zero tillage system was about half of the cost of the establishment using the conventional method. Also, the total cultivation cost of mungbean under zero tillage and conventional system were found Tk. 20715/ha and Tk. 26200/ha, respectively, which indicates that 20.9% production cost was saved under zero tillage system over the conventional method. Again, total income from mungbean cultivation under zero tillage system and conventional method were found Tk. 87325/ha and Tk.67585/ha, respectively. Further, net saving from mungbean cultivation under zero tillage system and the conventional method was Tk. 66610/ha and Tk. 41385/ha, respectively, which indicates that 60.9% higher net saving was generated from mungbean cultivation under zero tillage system. A similar trend of the result was obtained by Micheni et al. (2015) during on-farm experimentation on conservation agriculture in a maize- league cropping system. Furthermore, a higher benefit-cost ratio was obtained from the zero-tillage system (BCR = 3.2) than the conventional system (BCR=1.6) which indicates that zero tillage system is profitable than the conventional method. This result is following the results obtained by Uddin and Dhar (2016). Furthermore, it was also observed that zero tillage system is able to minimize turn-around time 8-10 days between previous harvesting and mungbean establishment, as the conventional method, needs about 10-12 days after harvesting of the previous crop for the establishment of mungbean. This result is following Hossain et al. (2015) who reported that zero tillage farming could minimize the average turn-around time 9-10 days between the two successive crops.

Table 4. The operational cost of zero-till drill

Parameters	Cost (Tk.)
1. Purchase price	40000
2. Salvage price	4000
3. Fixed cost [(i) + (ii) + (iii)], Tk/hr	25.75
Depreciation	17.15
Interest on investment	7.3
Shelter cost	1.3
4. Variable cost [(i) + (ii)], Tk./hr	157.7
Repair & Maintenance cost	7.7
Power tiller hiring cost	150
5. Total operational cost (No. 3 + No. 4) Tk./hr	182.5
6. Effective operating time, hr/ha	8.3
7. Operating cost (No. 5 * No. 6), Tk./ha	1515

Table 5. Economics of operation in Mungbean establishing method

Mungbean Establishing Method

Parameters	Zero-Till Drill Conventional Method	
	Un-ploughed	Ploughed
Land condition before planting/seeding	Un-ploughed	Ploughed
Land preparation (Tk./ha)	-	4400
Seed cost (Tk./ha) @Tk. 100/kg	3000	3550
Planting/Seeding cost (Tk./ha)	1515	450
Weeding cost (Tk./ha)	3200	4800
Fertilizer cost (Tk./ha)	4500	4500
Harvesting & Threshing cost (Tk./ha)	8500	8500
Total production cost (Tk./ha)	20715	26200
Grain yield (kg/ha)	1247.5	965.5
Total return (Tk./ha) @ Tk. 70/kg	87325	67585
Net saving (Tk/ha)	66610	41385
Production cost saving over the		
Conventional method (%)	20.9	-
Benefit cost ratio (BCR)	3.2	1.6

IV. Conclusion

This research focused on the performance evaluation of zero-till drill for the establishment of mungbean and comparing with the conventional method. Zero tillage system showed distinct advantages over the conventional method which was evaluated based on seed rate, planting cost, cost of production, yield, total income, net saving and BCR. Zero tillage system could save 5.5 kg of seed per hectare and maintains uniform line to line spacing and depth of planting. Mungbean yield under zero tillage system was found 30.4 % higher than the conventional method. Besides, mungbean planting cost and production cost under zero tillage system were 65.3% and 20.9% less than the conventional method. Also, zero tillage system increased net saving by 60.9% than the conventional method. Furthermore, a higher benefit-cost ratio was obtained from the zero-tillage system (BCR = 3.2) than the conventional system (BCR = 1.6) which indicates that Zero tillage system is profitable than the conventional method. Therefore, it can be concluded that mungbean establishment using zero tillage system is better than the conventional method.

References

- [1]. Ansari, M. S., Islam, M. H., Hossain, M. M., Ali, M. R. and Hossain, M. I. 2016. Zero-till drill for wheat establishment and comparison of performance with power tiller operated seeder (PTOS) and conventional method. *Journal of Agricultural Machinery and Bioresources Engineering*, 7 (1): 55-62.
- [2]. Bashour, A., Ali-Ouda, A., Kassam, A., Bachour, R. Touni, K., Hensmann, B. and Estephan, C. 2016. An overview of CA in the dry Mediterranean environment with special focus in Syria and Lebanon. *AIMS Agriculture and Food*, 1(1): 67- 84. <http://dx.doi.org/10.3934/agrfood.2016.1.67>
- [3]. Derpsch, R., Friedrich, T., Kassam, A. and Li, H. W. 2010. Current status of adoption of no-till farming in the world and some of its main benefits. *International Journal of Agricultural and Biological Engineering*, 3:1-25. <https://doi.org/10.25165/ijabe.v3i1.223>
- [4]. Hatfield, J. L. and Karlen, D. L. 1992. *Sustainable Agriculture Systems*. CRC Press, Boca Raton, Florida, USA.
- [5]. Hobbs, P. R, Sayre, K. and Gupta, R. 2008. The role of conservation agriculture on sustainable agriculture. *Philosophical Transactions of the Royal Society: Biological Science*, 363:543–555 <http://doi.org/10.1098/rstb.2007.2169>
- [6]. Hossain, M. I., Sarker, M. F. U. and Haque, M. A. 2015. Status of conservation agriculture- based tillage technology for crop production in Bangladesh. *Bangladesh Journal of Agricultural Research*, 40(2):235-248. <https://doi.org/10.3329/bjar.v40i2.24561>
- [7]. Hunt, D. 1995. *Farm Power and Machinery Management* (9th Edition). Iowa State University Press, USA.
- [8]. Iqbal, M. F., Hussain, M., Faisal, N., Iqbal, J., Rehman, A. U., Ahmad,
- [9]. M. and Padyar, J. A. 2017. Happy seeder zero tillage equipment for sowing wheat in standing rice stubbles. *International Journal of Advanced Research in Biological Sciences*, 4(4):101-105. <http://dx.doi.org/10.22192/ijarbs.2017.04.04.017>
- [10]. Michael, A. M. and Ojha, T. P. 1978. *Principle of Agriculture Engineering* (Vol. 1), Jain Brothers, New Delhi.
- [11]. Micheni, A. N., Kanampiu, F., Kitonyo, O, Mburus, O. M., Mugai, E.
- [12]. N. Makumbi, d. and Kassie, M. 2015. On-farm experimentation on conservation agriculture in maize-legume based cropping system in Kenya: Water use efficiency and Economic impacts. *Experimental Agriculture*, 52(1), 51-68. <http://doi:10.1017/S0014479714000556>
- [13]. Kahloon, M. H., Iqbal, M. F., Farooq, M., Ali, L. Fiaz, M. and Ahmad, I. 2012. A comparison of conservation technologies and traditional techniques for sowing of wheat. *Journal of Animal and Plant Science*, 22(3): 827-830. <http://www.thejaps.org.pk/docs/v-22-3/50.pdf>
- [14]. Kepner, R. A., Bainer, R. and Barger, E. L. 1978. *Principle of Farm Machinery* (3rd Edition). CBS Publishers & Distributors Pvt. Ltd, pp. 209-234.
- [15]. Naresh, R. K., Singh, S. P., Dwivedi, A., Sepat, N. K., Kumar, V., Ronaliya, L. K., Kumar, V. and Singh, R. 2013. Conservation agriculture improving soil quality for sustainable production systems under smallholder farming conditions in North West India: A review. *International Journal of Life Sciences Biotechnology and Pharma Research*, 2(4):151-213. <http://www.ijlbpr.com/index.php?m=content&c=index&a=show&catid=121&id=215>
- [16]. Qaisrani, S., Akbar, A. N., Ullah, E. and Rajtha, A. M. 2014. Cost analysis on wheat with operational time and fuel ingestion of different tillage practice in rice-wheat cropping system of Panjab, Pakistan, *Pakistan Journal of Life and Social Science*, 12(2): 114-119.
- [17]. Sharma, R. K., Chhokar, R. S., Singh, R. K. and Gill, S. C. 2008. Zero tillage wheat and unpuddled rice: the energy, labour and cost-efficient alternatives to conventional rice- wheat system. *Proceedings of the 14th Australian Agronomy Conference, Adelaide, South Australia*, pp. 147-158.
- [18]. Sidhu, H. S., Singh, M. Humphreys, E., Singh, Y., Singh, B., Dhillon, S. S., Blackwell, J., Bector, V., Singh, M. and Singh, S. 2007. The Happy Seeder enables direct drilling of wheat into rice stubble. *Australian Journal of Experimental Agriculture*, 47: 844-854. <https://doi.org/10.1071/EA06225>
- [19]. Singh, U. V., Kumar, D. and Moses, S. C. 2016. Performance evaluation of manually operated paddy drum seeder in puddled field. *ISOR Journal of Agriculture and Veterinary Science*, 9(6): 69-83. <https://www.iosrjournals.org/iosr-javs/papers/vol9- issue6/Version-2/K0906026983.pdf>
- [20]. Uddin, M. S., Amin, A. K. M. R., Ullah, M. J. and Asaduzzaman, M. 2009. Interaction effect of variety and different fertilizers on the growth and yield of summer mungbean. *American- Eurasian Journal of Agronomy*, 2(3):180-184. <https://doi.org/10.1.1.626.7036>
- [21]. Uddin, M. T. and Dhar, A. R. 2016. Conservation agriculture practices and its impacts on farmer's livelihood status in Bangladesh. *SAARC Journal of Agriculture*, 14(1): 119-140. <https://doi.org/10.3329/sja.v14i1.29582>
- [22]. USDA. 2018. FoodData Central: SR Legacy, Legumes and Legume Products, FDC ID: 174256, NDB Number:16080. <https://fdc.nal.usda.gov/fdc-app.html#/food-details/174256/nutrients>